

TEAMWORK

ACOUSTIC PENDANT

UP / DOWN

FITTING INFORMATION

Shade

Material: Aluminium
Colour: Flat White or Anthracite powder coat
Size: Ø800 x H75mm
Diffuser: Matt Opal Acrylic
Cleaning: Damp cloth with mild detergent

Fabric Insert Panel

Material: Woven Image Focus Fabric
Colour: Refer to Woven Image Focus Fabric colour chart
Size: OD Ø800mm, ID Ø500mm
Cleaning: Dust regularly

Acoustic Insert Panel

Optional Sound absorbing insert

Suspension - adjustable on installation

Flex & 3 Stainless Steel suspension:
Flex Colour: Clear
Length: 1075mm overall
Custom lengths available on request.

Canopy

Material: Aluminium
Colour: Flat White powder coat
Size: Ø80 x H30mm

Application

Indoor (IP20)

TECHNICAL DATA

Lamp

Led Module with integrated ECG

PHASE

3000K, L90@50,000+, 43W, 5710lm max
4000K, L90@50,000+, 43W, 6025lm max

DALI

3000K, L90@50,000+, 63W, 8130lm max
4000K, L90@50,000+, 63W, 8520lm max

Higher outputs available upon request.

Switching & Dimming

Switching: Hardwired to power supply, wall switched
Dimming: Integrated DALI and Leading or Trailing edge
Phase dimming options only

.IES & .RFA files upon request

ORDER INFO

Product range - Model number - Finish/Colour

Dimming/Finish	Flat White	Anthracite
Phase	TW-P22-116	TW-P22-132
DALI	TW-P23-116	TW-P23-132

Optional Acoustic insert panel TW-P90-000

When ordering please specify lamp colour temperature and Focus Fabric colour required (TW-P95-000).



DIMENSIONAL DRAWING

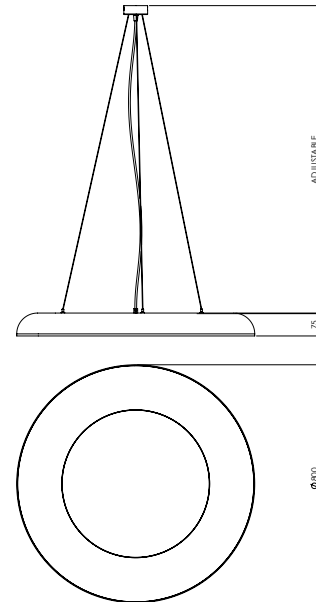

PHOTOMETRIC DATA

Teamwork Up-Down PHASE 4000K

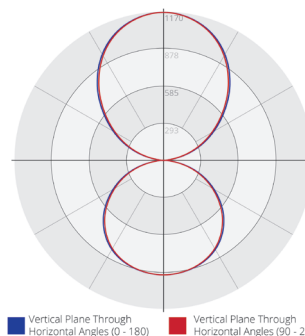

Vertical Plane Through Horizontal Angles (0 - 180) Vertical Plane Through Horizontal Angles (90 - 270)

Teamwork Up-Down DALI 4000K

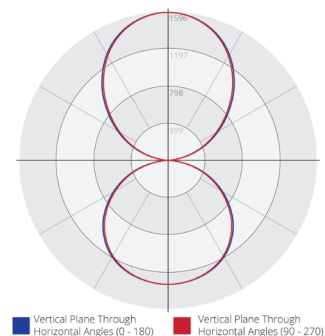

Vertical Plane Through Horizontal Angles (0 - 180) Vertical Plane Through Horizontal Angles (90 - 270)

ISM

www.ismobjects.com.au

©2022

Specifications are subject to change without notice.

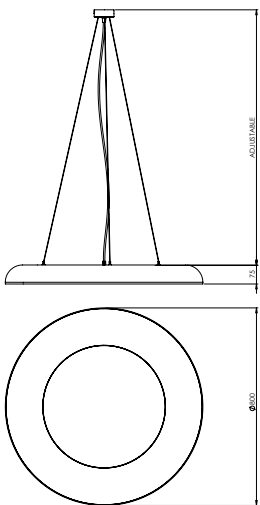

TEAMWORK

ACOUSTIC PENDANT

Teamwork pendant combines the latest LED lighting technology with sound absorbing material perfect for working and meeting zones that want to reduce ambient noise.

The simple form of Teamwork includes a fabric insert panel with no visible fixings, available in a choice of colours.

The pendant is highly customisable with a choice of lighting directions, fabric finishes and dimming control options.

ism

www.ismobjects.com.au

©2022

Specifications are subject to change without notice.