

# STUDIO 8

## FLOOR LAMP

### FITTING INFORMATION

#### Base

Material : Mild steel  
Colour Option: Flat Black Powder Coat  
Size : Ø400mm  
Cleaning : Damp cloth with mild detergent

#### Stem

Material : Aluminium  
Colour Option: Anodised Black  
Size : Ø19mm x H1500mm  
Cleaning : Damp cloth with mild detergent

#### Shade

Material: Aluminium  
Size: Ø200mm x H140mm  
Colour: External Shade - Anodised Black  
Internal Shade - Flat White powder coat  
Cleaning: Damp cloth with mild detergent

#### Flex cable

Material: Black Fabric Flex

#### Application

Indoor (IP20)

### TECHNICAL DATA

#### Lamp

LED Retrofit GU10, 3000K, 5.5W, 240V, 380lm

#### Switching & Dimming

Switching: On fitting rocker switch, located top of shade

.IES & .RFA files upon request

### ORDER INFO

Product range - Model number - Finish/Colour

Studio 8 Floor Lamp	Anodised Black with Brass
	S8-F01-515



### DIMENSIONAL DRAWING

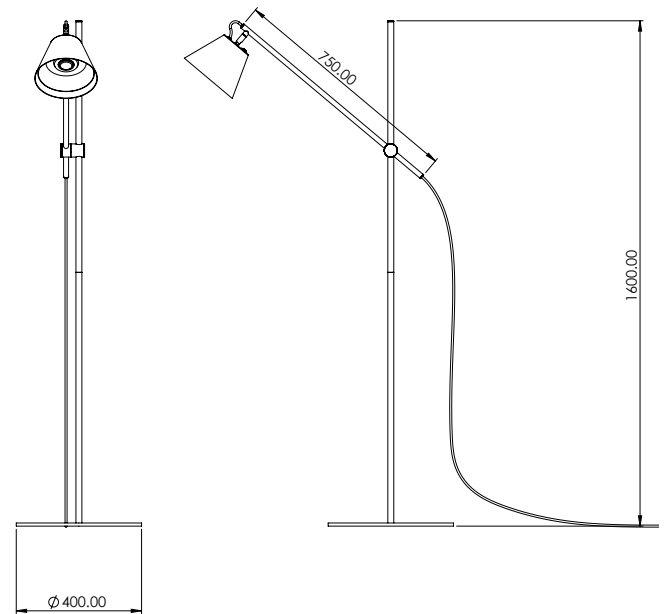

### PHOTOMETRIC DATA

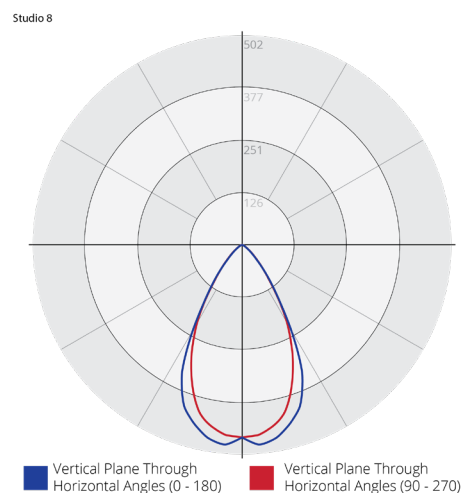



# STUDIO 8

## FLOOR & WALL LAMP

Aluminium stem, arm and spun shades with a steel base. Offered in a choice of flat black powder coat with brass locking screws.

