

# CLOCHE

## PENDANT

### MEDIUM

#### FITTING INFORMATION

##### SHADE

Material : Aluminium  
 External colour : Traffic White, Marine, Signal Orange, Quartz Grey powder coat  
 Internal colour : Gloss White  
 Size : Ø500mm x H250mm  
 Diffuser : Flush fitted Matt White acrylic  
 Cleaning : Damp cloth with mild detergent

##### Suspension - adjustable on installation

Clear Flex & 3 Stainless Steel Cable Suspension  
 Flex Colour: Clear  
 Length: 1250mm Overall  
 Custom lengths available on request.

##### Canopy

Material: Aluminium  
 Finish: White Powder Coat  
 Size: Ø80mm x H30mm

##### Application

Indoor (IP20)

#### TECHNICAL DATA

##### Lamp

Led Module with integrated ECG

PHASE  
 3000K, L90@50,000+, 25.2W, 2965lm max  
 4000K, L90@50,000+, 25.2W, 2960lm max

DALI  
 3000K, L90@50,000+, 37.8W, 4455lm max  
 4000K, L90@50,000+, 37.8W, 4530lm max

##### Switching & Dimming

Switching: Hardwired to power supply, wall switched  
 Dimming: Integrated DALI and Leading or Trailing edge  
 Phase dimming options only

.IES & .RFA files upon request

#### ORDER INFO

##### Product range - Model number - Finish/Colour

(External/Internal)	Traffic White/White	Marine/White	Quartz Grey/White	Signal Orange/White
Medium Phase Dim	CH-P03-129	CH-P03-130	CH-P03-131	CH-P03-132
Medium DALI Dim	CH-P04-129	CH-P04-130	CH-P04-131	CH-P04-132

Please specify lamp colour temperature required.



#### DIMENSIONAL DRAWING

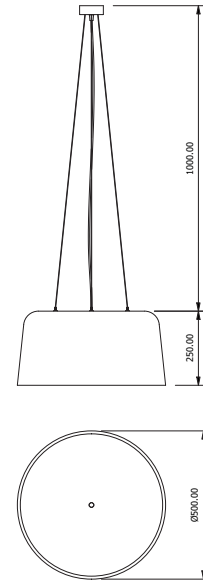

#### PHOTOMETRIC DATA

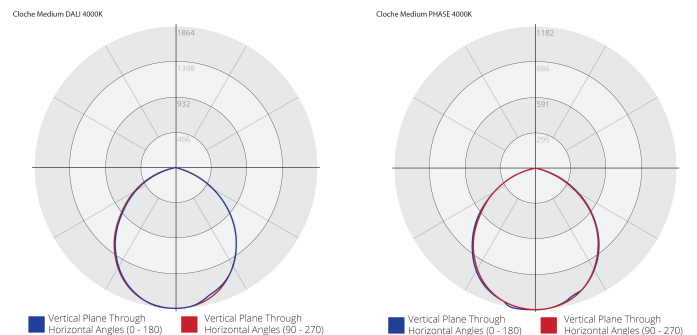

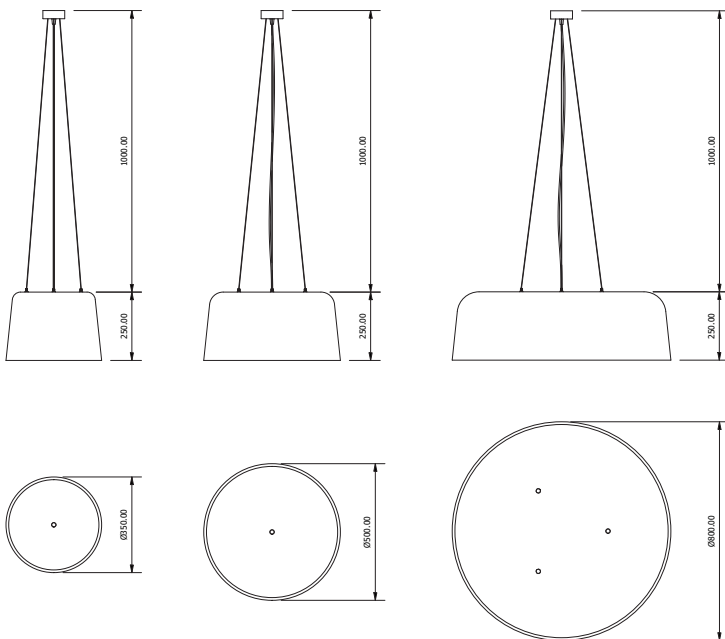

# CLOCHE PENDANT

Spun aluminium shade is available with gloss white interior and a variety of exterior powdercoat colours.

**ism**

[www.ismobjects.com.au](http://www.ismobjects.com.au)

©2023

Specifications are subject to change without notice.